



HP 75000 SERIES B and C

Eight-Channel Programmable Filter and Gain Signal Conditioning Plug-on HP E1503A

User's Manual

The HP E1503 manual also applies to HP E1413Bs as HP E1413 Option 13.

Enclosed is the User's Manual for the HP E1503 Signal Conditioning Plug-on. Insert this manual in your HP E1413/E1313, or HP E1415 manual behind the "Signal Conditioning Plug-ons" divider.



Copyright © Hewlett-Packard Company, 1993, 1994, 1995, 1996, 1997



E1503-90002

HP E1503A

Eight-Channel Programmable Filter and Gain Signal Conditioning Plug-on

Introduction

The HP E1503 is a Signal Conditioning Plug-on that provides eight programmable low-pass filters with cutoff frequency settings of 2, 10, and, 100 Hertz, as well as a 1.5KHz “pass-through” mode (filter OFF). The eight programmable input amplifiers provide gains of 1, 8, and 64. Also provided is input over-voltage protection and open transducer detection on each channel.

About this Manual

Except where noted, all references to the HP E1413 apply to the HP E1313 and HP E1415. This manual shows you how to control the Signal Conditioning Plug-on (SCP) using SCPI commands as well as Register-Based commands, and explains the capabilities of this SCP. Finally, it covers specifications for this SCP. The contents of this manual are:

- Installation 3
- Identifying the Plug-on 3
- Connecting To The Terminal Module 4
- Programming With SCPI Commands 6
- Programming With Register Commands 10
- Specifications 12

Installation

Installation for this Plug-on is common to several others and is covered in Chapters 1 and 2 of your HP E1413/E1313 manual.

Identifying the Plug-on

You’ll find the HP part number on the connector side of the SCP to the left of the serial number bar code. For the HP E1503, the part number is :
E1413-63513

Connecting To The Terminal Module

This section shows how to make connections to the Terminal Module.

The SCP connections for the Terminal Modules are shown on the stick-on labels that came with the SCP. Use the appropriate label for the type of Terminal Module you have. The connections and appropriate stickers are as follows:

- For HP E1413C and above Terminal Modules, use stickers for HP E1503 SCPs. The connections are shown in Figure 1.
- For HP E1313 Terminal Modules, use stickers for HP E1503 SCPs. The connections are shown in Figures 2 and 3.
- For HP E1413B and below Terminal Modules, use stickers for HP E1413 Option 13 SCPs. The connections are shown in Figure 4.

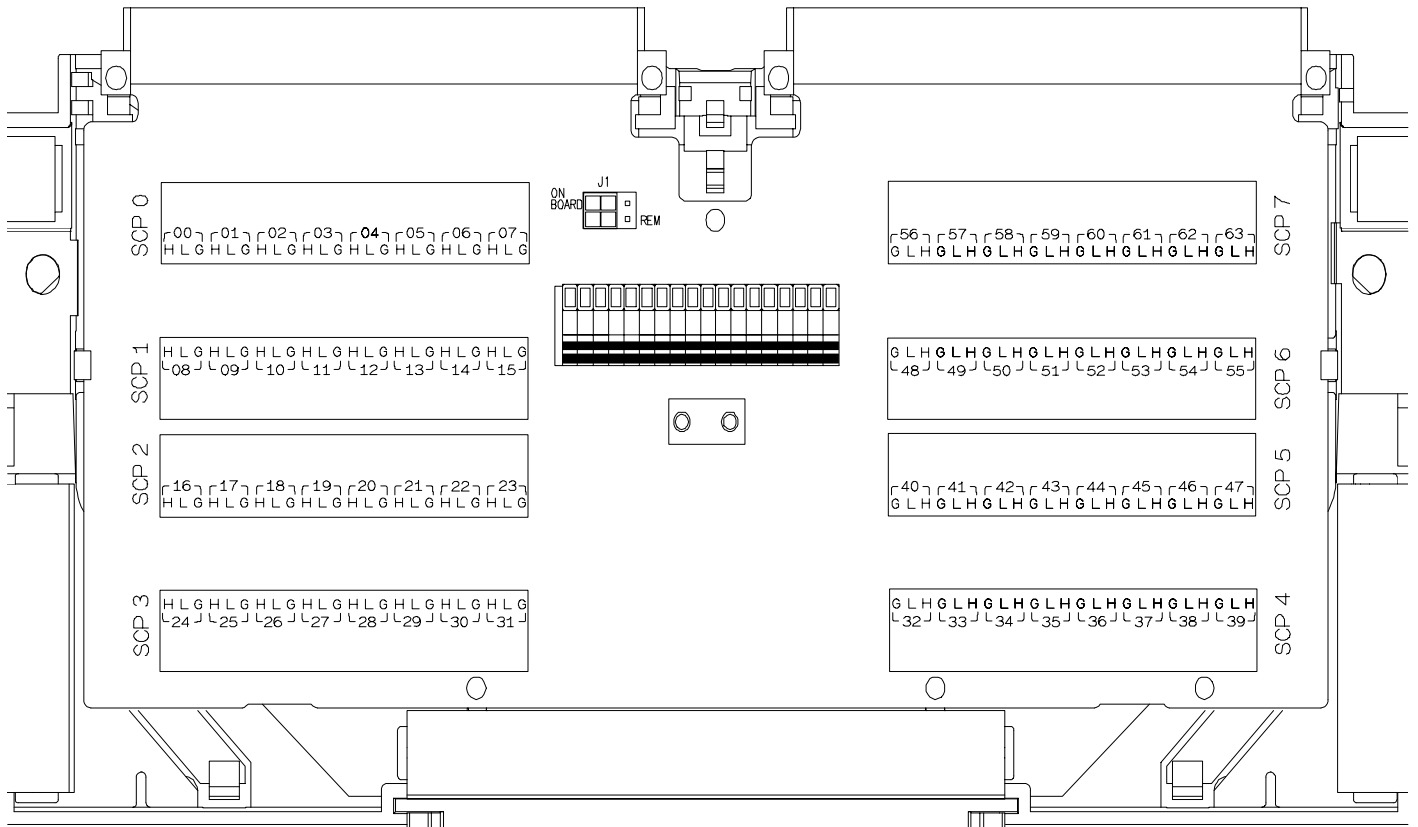

Figure 1 HP E1503 C-Size Terminal Module Connections

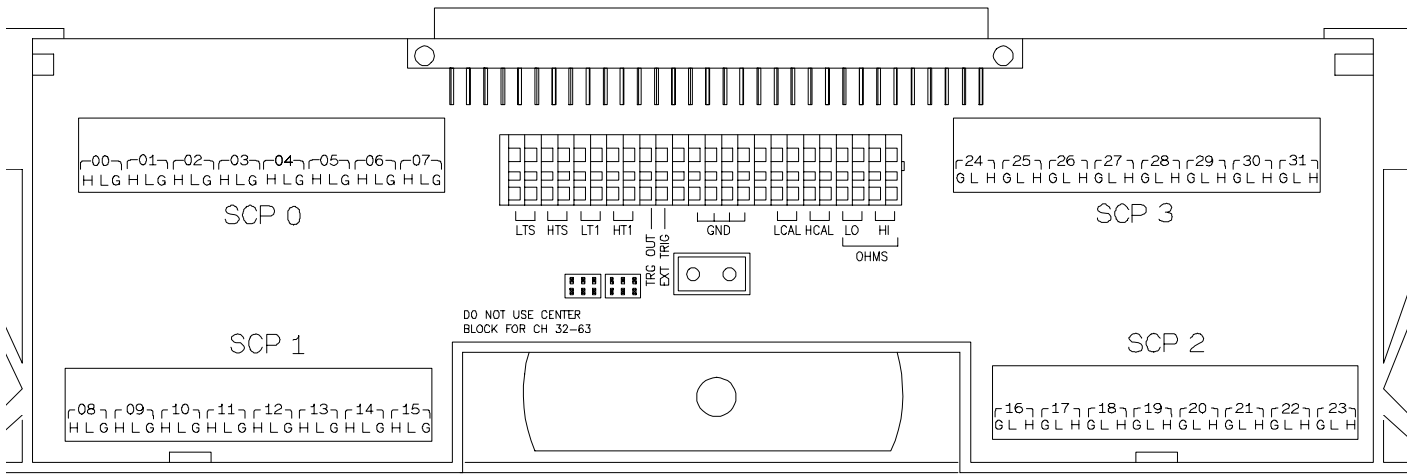

Figure 2 HP E1503 B-size Terminal Module Connections (Ch 00-31)

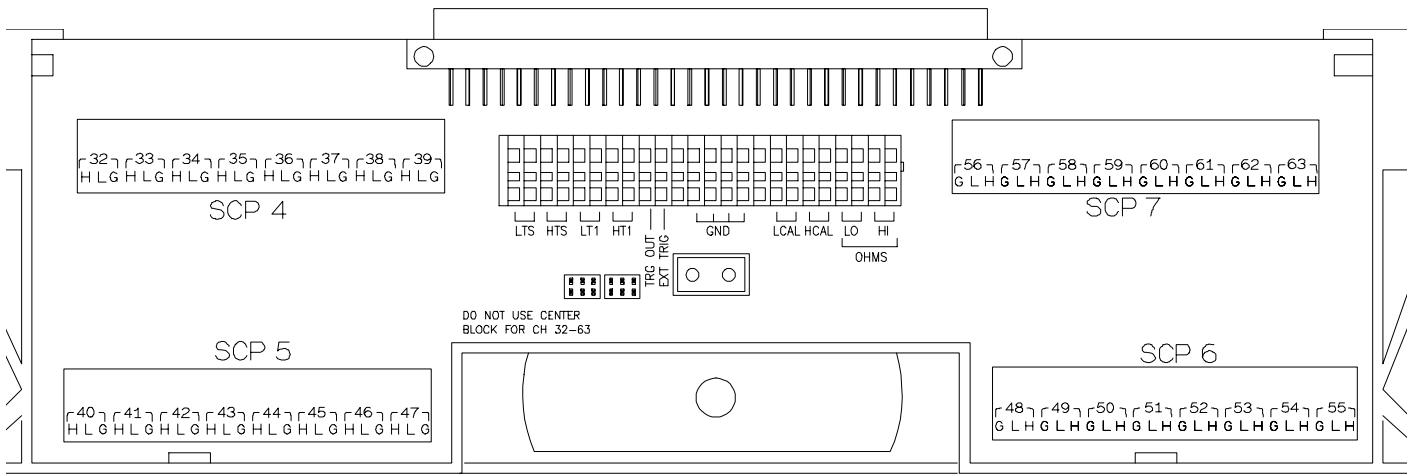

Figure 3 HP E1503 B-size Terminal Module Connections (Ch 32-63)

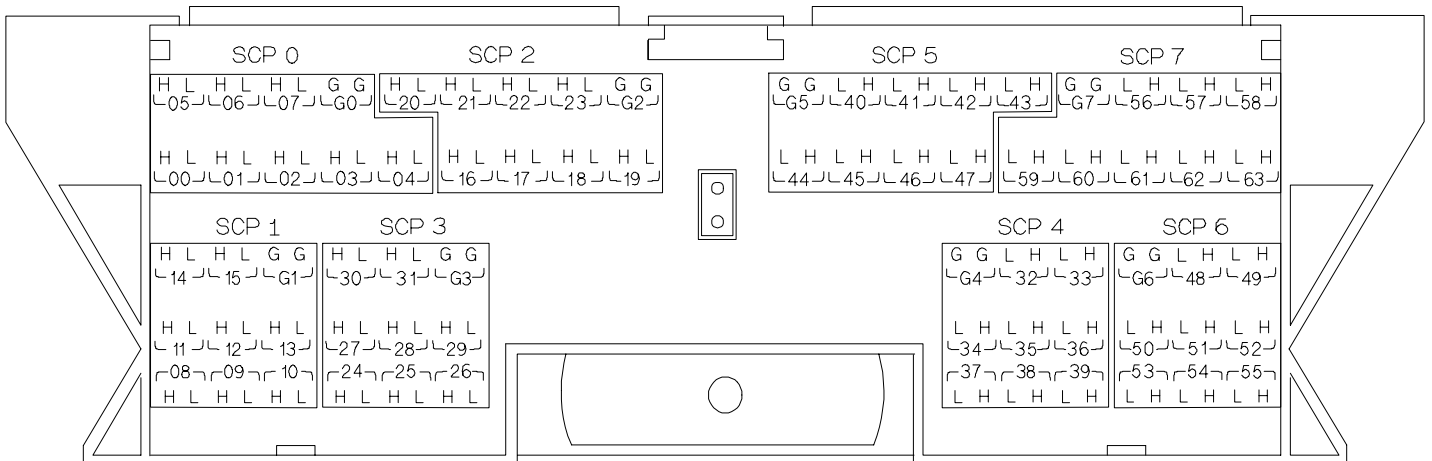

Figure 4 HP E1413 Option 13 Terminal Module Connections

Programming With SCPI Commands

The SCPI commands shown here are covered in Chapters 3 and 5 of your HP E1413/E1313 manual. This section will relate those commands to the parameter values which are specific to this Plug-on.

Checking the ID of the SCP

To verify the SCP type(s) installed on the HP E1413/E1313 use the SYSTem:CTYPe? (@<channel>) command.

- The *channel* parameter specifies a single channel in the channel range covered by the SCP of interest. The first channel number for each of the eight SCP positions are; 0,8,16,24,32,40,48, and 56.

The value returned for the SCP in an HP E1413B is:
HEWLETT-PACKARD,E1413 Opt 13 8-Channel Amp+Filter SCP,0,0

The returned value for the SCP in an HP E1413C/E1313A is:
HEWLETT-PACKARD,E1502 8-Channel Amp+Filter SCP,0,0

To determine the type of SCP installed on channels 0 through 7 send

```
SYST:CTYP? (@100)           query SCP type @ ch 0
enter statement here         enter response string
```

Setting the Filter Cutoff Frequency

To set the channel cutoff frequency use the INP:FILTer[:LPASs]:FREQuency <cutoff>, (@<ch_list) command.

- The *cutoff* parameter can specify 2, 10, 100, MIN or MAX. MIN will specify 2 Hz while MAX will specify 100 Hz.

To set channels 0 through 15 and 24 to the 2 Hz cutoff frequency and channels 16 through 23 to the 100 Hz cutoff frequency send

```
INP:FILT:FREQ 2, (@100:115,124)   send separate command
INP:FILT:FREQ 100, (@116:123)     per cutoff frequency
```

or to combine into a single command message

```
INP:FILT:FREQ 2, (@100:115,124);FREQ 100, (@116:123)
```

NOTE

The *RST and Power-On condition for cutoff frequency is MIN for all channels.

Querying the Filter Cutoff Frequency

To query any channel for its cutoff frequency use the INPut:FiLTeR[:LPASs]:FREQuency? (@<channel>) command. The INP:FILT:FREQ? command returns the numeric cutoff value currently set for the channel specified.

- The *channel* parameter must specify a single channel.

To query the cutoff frequency of channel 6 send

```
INP:FILT:FREQ? (@106)           query channel 6
enter statement here           returns 2, 10, or 100
```

Enabling and Disabling the Filter

To enable and disable channel filters use the INPut:FiLTeR[:LPASs][:STATe] <enable>, (@<ch_list>) command.

- The *enable* parameter can specify ON or OFF

To enable channels 0 through 15 and 20 to filter, send

```
INP:FILT ON, (@0:115,120)       channels filtering as set by
                                INP:FILT:FREQ
```

To disable channels 0 through 8 send

```
INP:FILT OFF, (@100:108)       channels 0-8 are now in
                                pass-through mode
```

NOTES

1) INP:FILT ON is the *RST and Power-On condition for all filter channels.

2) INP:FILT OFF has a low-pass filter characteristic of approximately 1.5KHz and limitations to signal levels. It is intended primarily for diagnostic use.

Querying the Filter State

To query any channel to determine if it is enabled or disabled use the INPut:FiLTeR[:LPASs][:STATe]? (@<channel>) command. The INP:FILT? command returns a 0 if the channel is OFF or a 1 if the channel is ON.

- The *channel* parameter must specify a single channel.

To query the filter state of channel 2 send

```
INP:FILT? (@102)               query channel 2
enter statement here           returns 0 or 1
```

Setting the Amplifier Gain

To set the channel gain use the INPut:GAIN <gain>, (@<ch_list>) command.

- The *gain* parameter can specify 1, 8, 64, MIN, or MAX. MIN specifies 1 while MAX specifies 64. Note that the gain choices for this SCP are multiples of 8 to complement the HP E1413/E1313's A/D range choices which are multiples of 4. The following table shows the gain and range combinations.

A/D Range → ↓ SCP Gain ↓	16V (A/D gain 1)	4V (A/D gain 4)	1V (A/D gain 16)	.25V (A/D gain 64)	.0625V (A/D gain 256)
1	1	4	16	64	256
8	8	32	128	512	2,048
64	64	256	1,024	4,096	not allowed

To set channels 32 through 47 and 63 to a channel gain of 8 and channels 48 through 55 to a channel gain of 64 send

```
INP:GAIN 8, (@132:147,163)           send separate command  
INP:GAIN 64, (@148:155)             per gain factor
```

Querying the Amplifier Gain

To query any channel to determine its gain setting use the INPut:GAIN? (@<channel>) command. The INP:GAIN? command returns the current gain value for the specified channel.

- The channel parameter must specify a single channel.

To query the gain setting of channel 8 send

```
INP:GAIN? (@108)                       query channel 8  
enter statement here                   returns 1, 8, or 64
```

Detecting Open Transducers

This SCP provides a method to detect open transducers. When Open Transducer Detect (OTD) is enabled, the SCP injects a small current into the HIGH and LOW input of each channel. The polarity of the current pulls the HIGH inputs toward +17 volts and the LOW inputs towards -17 volts. If a transducer is open, measuring that channel will return an over-voltage reading. OTD is available on a per SCP basis. all eight channels of an SCP are enabled or disabled together. See Figure 5 for a simplified schematic diagram of the OTD circuit.

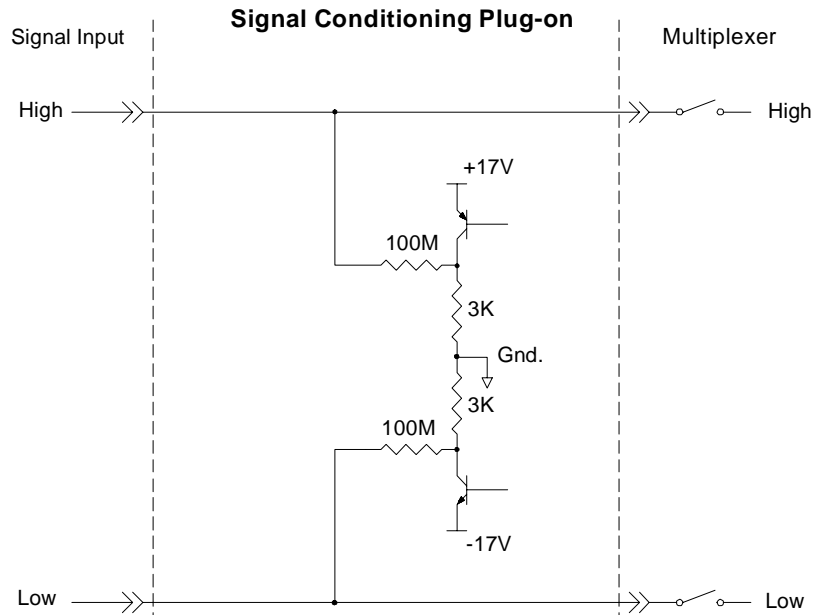

Figure 5 Open Transducer Detect Circuit

NOTES

- 1) When OTD is enabled, the inputs have up to $0.2\mu\text{A}$ injected into them. If this current will adversely affect your measurement, but you still want to check for open transducers, you can enable OTD, make a single scan, check the CVT for bad measurements, then disable OTD and make your regular measurement scans. The specifications apply only when OTD is off.
- 2) When Filtering is enabled, allow 15 seconds or the filter capacitors to charge before checking for open transducers.

To enable or disable Open Transducer Detection, use the DIAGnostic:OTDetect *<enable>*, (@*<ch_list>*) command.

- The *enable* parameter can specify ON or OFF
- An SCP is addressed when the *ch_list* parameter specifies a channel number contained on the SCP. The first channel on each SCP is: 0, 8, 16, 24, 32, 40, 48, and 56

To enable Open Transducer Detection on all channels on SCPs 1 and 3:

DIAG:OTD ON, (@100,116) *0 is on SCP 1 and 16 is on SCP3*

To disable Open Transducer Detection on all channels on SCPs 1 and 3:

DIAG:OTD OFF, (@100,116)

Register Based Programming

The register-based commands shown here are covered in Appendix D of the HP E1413/E1313 manual. You should read that section first to become familiar with accessing registers and executing Register-Based Commands. This section will relate those commands to the parameter values which are specific to this Plug-on.

When Register Programming an SCP most communication is through the Signal Conditioning Bus. For that you will use the Register Commands:

SCBWRITE <regaddr> <regvalue>
and
SCBREAD? <regaddr>

HP E1503 Register Map

Read (returned value)	Write(<regvalue>)	SCP Register	<regaddr> Value
SCP ID (E0E0 ₁₆)		Whole SCP Reg 0	00ppp000000 ₂
SCP Gain Scale (XXX3 ₁₆)		Whole SCP Reg 1	00ppp000001 ₂
Channel Gain (XXX0 ₁₆ =1, XXX1 ₁₆ =8, XXX2 ₁₆ =64)		Channel Reg 1	01ppppcc001 ₂
Channel Frequency (XXX0 ₁₆ =2Hz, XXX1 ₁₆ =10Hz, XXX2 ₁₆ =100Hz, XXX3 ₁₆ =Straight Through)		Channel Reg 2	01ppppcc010 ₂

XX=don't care

ppp=Plug-on
ccc=SCP channel

In addition you will access bits in the Card Control register to control Open Transducer Detection.

Checking ID of SCP

To query an SCP for its ID value, write the following value to Parameter Register 1:

$$(SCP\ number) \times 40_{16}$$

Then write the opcode for SCBREAD? (0800₁₆) to the Command Register. The ID value will be written to the Query Response Register.

Setting the Filter Cut-Off

To set the filter cut-off frequency for an SCP channel, write the following SCP channel address to Parameter Register 1:

$$200_{16} + (SCP\ number) \times 40_{16} + (SCP\ channel\ number) \times 8_{16} + 2_{16}$$

Write one of the following cut-off values to Parameter Register 2:

0000₁₆ for 2Hz, 0001₁₆ for 10Hz, 0002₁₆ for 100Hz,
0003₁₆ for Straight Through

Then write the opcode for SCBWRITE (0810₁₆) to the Command Register.

Setting the Amplifier Gain

To set the amplifier gain for an SCP channel, write the following SCP channel address to Parameter Register 1:

$$200_{16} + (SCP\ number) \times 40_{16} + (SCP\ channel\ number) \times 8_{16} + 1_{16}$$

Write one of the following gain values to Parameter Register 2:

0000₁₆ for 1, 0001₁₆ for 8, 0002₁₆ for 64

Then write the opcode for SCBWRITE (0810₁₆) to the Command Register.

Detecting Open Transducers

Open Transducer Detection (OTD) is controlled by bits in the Card Control Register. For more information on OTD see Figure 1.

Card Control Register

(Base + 1216)

15	14	14-13	12	11	10-8	7-0
PSI Pwr Reset	FIFO Mode	unused	FIFO Clear	VPPEN	A24 Window	Open Transducer Detect

Writing a one (1) to a bit enables open transducer detect on that signal conditioning module. Writing a zero (0) to a bit disables open transducer detect.

Bit 7	Bit 6	Bit 5	Bit 4	Bit 3	Bit 2	Bit 1	Bit 0
SCP 7	SCP 6	SCP 5	SCP 4	SCP 3	SCP 2	SCP 1	SCP 0

Specifications

These specifications for the HP E1503 reflect the combined performance of the HP E1413/E1313 and the E1503 Signal Conditioning Plug-on. These specifications are not to be added to those presented in the HP E1413/E1313 User's Manual.

General Specifications

SCP Current Requirements (in Amps)	5Vmax 0.01	24Vtyp 0.04	24Vmax 0.06	-24Vtyp 0.04	-24Vmax 0.06
--	---------------	----------------	----------------	-----------------	-----------------

Measurement ranges

DC Volts	±3.9mV to ±16V FS
Temperature	Thermocouples - -200 to +1700 °C Thermistors - (Opt 15 required) -80 to +160 °C RTD's - (Opt 15 required) -200 to +850 °C
Resistance	(Opt 15 required) 128 ohms to 131 Kohms FS
Strain	25,000 µe or limit of linear range of strain gage

Maximum input voltage (Normal mode plus common mode)	Operating: < ±16 V peak	Damage level: > ±42 V peak
--	-------------------------	----------------------------

Maximum common mode voltage	Operating: < ±16 V peak	Damage level: > ±42 V peak
------------------------------------	-------------------------	----------------------------

Normal mode rejection	2Hz Filter	10Hz Filter	100Hz Filter	Filter Off
	@ 2Hz -3dB @ 60Hz >-45dB	@ 10Hz -3dB @ 60Hz >-20dB	@ 100Hz -3dB @ 400Hz -15dB	@ 1.5KHz approx -3dB

Common mode rejection (0-60Hz)	Gain X1	Gain X8	Gain X64
	> -100dB	>-116dB	>-132dB

Input impedance	100 Mohm ±10% (each differential input to ground)
------------------------	---

Maximum tare cal offset	(Maximum tare offset depends on A/D range and SCP gain)
--------------------------------	---

A/D range ±V F.Scale	Offset V Gain x1	Offset V Gain x8	Offset V Gain x64
16	3.2213	.40104	.04970
4	.82101	.10101	.01220
1	.23061	.02721	.00297
.25	.07581	.00786	.00055
.0625	.03792	.00312	n/a

**Measurement accuracy
DC Volts**

(90 days) 23°C ±1°C (with *CAL? done after 1 hr warm up and CAL:ZERO? done within 5 min.). If autoranging is ON, add ±.02% FS to accuracy specifications.
For E1313, multiply Noise Spec. by 1.4.

Gain X1

Range ±V FS	Linearity % of rdg	Offset Error				Noise 3 sigma	Noise* 3 sigma
		2Hz	10Hz	100Hz	Filt Off		
.0625	0.01%	13 µV	9.5 µV	6.8 µV	6.3 µV	45 µV	26 µV
.25	0.01%	15 µV	12.5 µV	11.2 µV	10.8 µV	63 µV	31 µV
1	0.01%	33 µV	31.8 µV	31.3 µV	31.2 µV	112 µV	93 µV
4	0.01%	123 µV	122 µV	122 µV	122 µV	450 µV	366 µV
16	0.01%	488 µV	488 µV	488 µV	488 µV	1.8 mV	1.5 mV

* [SENSe:]FILTer[:LPASs][:STATe] ON (max scan rate - 100 rdgs/sec/channel)

Temperature Coefficients: Gain - 15 ppm/°C after *CAL?. Offset - Add tempco + fixed offset to offset above

Temp	Tempco	2Hz	10Hz	100Hz	Filt Off
0-30 °C	.16µV/°C	0µV	0µV	0µV	0µV
30-40 °C	.18µV/°C	13µV	9µV	1.1µV	.2µV
40-55 °C	.39µV/°C	31µV	22µV	6.4µV	1.1µV

Gain X8

Range ±V FS	Linearity % of rdg	Offset Error				Noise 3 sigma	Noise* 3 sigma
		2Hz	10Hz	100Hz	Filt Off		
.0078	0.01%	4.6 µV	4.2 µV	3.8 µV	3.7 µV	5.8 µV	4.9 µV
.031	0.01%	4.8 µV	4.6 µV	4.4 µV	4.3 µV	6.9 µV**	5.9 µV**
.125	0.01%	6 µV	5.3 µV	5 µV	4.9 µV	14 µV	12 µV
.5	0.01%	16 µV	16 µV	16 µV	16 µV	56 µV	46 µV
2	0.01%	61 µV	61 µV	61 µV	61 µV	225 µV	188 µV

* [SENSe:]FILTer[:LPASs][:STATe] ON (max scan rate - 100 rdgs/sec/channel)

** 7.4 µV and 6.3 µV when temp >= 40°C

Temperature Coefficients: Gain - 15 ppm/°C after *CAL?. Offset - Add tempco + fixed offset to offset above

Temp	Tempco	2Hz	10Hz	100Hz	Filt Off
0-30 °C	.16µV/°C	0µV	0µV	0µV	0µV
30-40 °C	.18µV/°C	4.3µV	2.7µV	1µV	.2µV
40-55 °C	.39µV/°C	13µV	10µV	6.2µV	.8µV

Gain X64

Range ±V FS	Linearity % of rdg	Offset Error				Noise 3 sigma	Noise* 3 sigma
		2Hz	10Hz	100Hz	Filt Off		
.0039	0.01%	2.9 µV	2.3 µV	2.1 µV	2.1 µV	1.6 µV**	1.3 µV**
.0156	0.01%	3 µV	2.4 µV	2.2 µV	2.2 µV	2.2µV***	1.9µV***
.0625	0.01%	3.5 µV	3 µV	2.9 µV	2.9 µV	7 µV	5.7 µV
.25	0.01%	8.2 µV	8 µV	8 µV	8 µV	28 µV	23 µV

* [SENSe:]FILTer[:LPASs][:STATe] ON (max scan rate - 100 rdgs/sec/channel)

** 1.9 µV and 1.7 µV for 100 Hz Filter

*** 2.5 µV and 2.2 µV when temp >= 40°C

Temperature Coefficients: Gain - 15 ppm/°C after *CAL?. Offset - Add tempco + fixed offset to table above

Temp	Tempco	2Hz	10Hz	100Hz	Filt Off
0-30 °C	.16µV/°C	0µV	0µV	0µV	0µV
30-40 °C	.18µV/°C	1.1µV	.2µV	.1µV	.1µV
40-55 °C	.39µV/°C	6µV	1.4µV	.6µV	.6µV

**Measurement accuracy
Temperature**

(90 days) 23°C ±1°C (with *CAL? done after 1 hr warm up and CAL:ZERO? within 5 min.). If autoranging is ON, add ±.02% FS to accuracy specifications.

(simplified specifications, see temperature accuracy graphs in HP E1413/E1313 manual for details)

The temperature accuracy specifications include instrument and firmware linearization errors. The linearization algorithm used is based on the IPTS-68(78) standard transducer curves. Add your transducer accuracy to determine total measurement error.

Thermocouples

NOTE: ALL Thermocouple Specifications Use Gain X64

Type E	A/D Filter	-200 to 0 °C	0 to 200 °C	200 to 400 °C	400 to 800 °C
	OFF ON*	1.25°C 1.20°C	0.10°C 0.095°C	0.12°C 0.10°C	0.125°C 0.11°C
Type EEXtended	A/D Filter	-200 to 0 °C	0 to 200 °C	200 to 800 °C	800 to 1000 °C
	OFF ON*	13.4°C 13.3°C	0.30°C 0.25°C	0.20°C 0.15°C	0.35°C 0.30°C
Type J	A/D Filter	-200 to 0 °C	0 to 280 °C	280 to 600 °C	600 to 775 °C
	OFF ON*	1.50°C 1.47°C	0.10°C 0.11°C	0.15°C 0.15°C	0.17°C 0.15°C
Type K	A/D Filter	-200 to 0 °C	0 to 375 °C	375 to 800 °C	800 to 1400°C
	OFF ON*	2.25°C 2.70°C	0.15°C 0.15°C	0.20°C 0.17°C	0.25°C 0.25°C
Type R	A/D Filter	0 to 100 °C	100 to 200 °C	200 to 600 °C	600 to 1000 °C
	OFF ON*	1.40°C 1.40°C	0.75°C 0.70°C	0.45°C 0.40°C	0.30°C 0.30°C
Type S	A/D Filter	0 to 100 °C	100 to 200 °C	200 to 800 °C	800 to 1750 °C
	OFF ON*	2.85°C 2.85°C	1.35°C 1.80°C	0.70°C 0.65°C	0.65°C 0.55°C
Type T	A/D Filter	-200 to -100°C	-100 to 0 °C	0 to 200 °C	200 to 400 °C
	OFF ON*	1.35°C 1.35°C	0.25°C 0.22°C	0.10°C 0.10°C	0.15°C 0.13°C

* [SENSe:]FILTer[:LPASs][:STATe] ON (max scan rate - 100 rdgs/sec/channel)

**Measurement accuracy
Temperature (cont.)**

(simplified specifications, see temperature accuracy graphs in HP E1413/E1313 manual for details)

Thermistors

5KΩ Reference Thermistor Use Gain X8

A/D Filter	0 to 45 °C	45 to 65 °C	65 to 85 °C
OFF	0.0035 °C	0.0045°C	0.0072°C
ON*	0.0035 °C	0.0045°C	0.0068°C

100Ω Reference RTD Use Gain X64

A/D Filter	-125 to 70°C
OFF	0.080°C
ON*	0.080°C

100Ω RTD Use Gain X64

A/D Filter	-200 to 75 °C	75 to 300 °C	300 to 600 °C	600 to 970 °C
OFF	0.08°C	0.21°C	0.27°C	0.37°C
ON*	0.07°C	0.18°C	0.25°C	0.35°C

2252Ω Thermistor Use Gain X8

A/D Filter	10 to 40 °C	40 to 70 °C	70 to 83 °C	83 to 100 °C
OFF	0.0055°C	0.0065°C	0.0077°C	0.010°C
ON*	0.0055°C	0.0065°C	0.0077°C	0.010°C

5KΩ Thermistor Use Gain X8

A/D Filter	-10 to 20 °C	20 to 40 °C	40 to 65 °C	65 to 85 °C
OFF	0.0085°C	0.010°C	0.016°C	0.018°C
ON*	0.0082°C	0.010°C	0.015°C	0.018°C

10KΩ Thermistor Use Gain X8

A/D Filter	0 to 30 °C	30 to 60 °C	60 to 90 °C	90 to 115 °C
OFF	0.010°C	0.012°C	0.018°C	0.022°C
ON*	0.010°C	0.012°C	0.018°C	0.021°C

Notes
